



DAVE LENNOX
signature[™]
COLLECTION

Home Comfort Systems



XC21

The most quiet and efficient central air conditioner you can buy*

Optimized for use with the exclusive Humiditrol[®] whole-home dehumidifier system—air quality you can feel



HOME COMFORT SYSTEMS
Innovation never felt so good.™

Dave Lennox Signature™ Collection XC21 Air Conditioner

Innovation never felt so good.™

Patented SilentComfort™ technology for quiet cooling

Two-stage operation for optimal performance and efficiency

Outstanding efficiency can save you hundreds of dollars each year

Ozone-responsible R410A refrigerant meets the EPA's (Environmental Protection Agency) most stringent environmental guidelines

Optimized for use with the exclusive Humiditrol® whole-home dehumidifier system

Lennox® System Operations Monitor reviews system performance for additional peace of mind and faster, easier service

SmartHinge™ louvered access panels for improved coil protection and fast, efficient servicing

ENERGY STAR®-qualified

Want to beat the heat and high utility bills, without sacrificing comfort?

The XC21 air conditioner more than delivers. Now offering an even greater level of comfort and efficiency, the XC21 takes cooling technology to new heights, so your utility bills reach new lows.

THE MOST QUIET AND EFFICIENT CENTRAL AIR CONDITIONER YOU CAN BUY*

Enhanced with innovative new features, the XC21 provides ultrahigh-efficiency cooling with two stages of operation. It runs at low stage 80% of the time to reduce energy costs and sound levels. Two-stage operation and exclusive SilentComfort™ technology provide optimal performance for efficient, quiet cooling.

Efficient Can save hundreds of dollars each year on utility bills

With industry-leading efficiencies of up to 20.50 SEER, the XC21 is nearly twice as efficient as a typical*** air conditioner. That means the XC21 can lower your utility bills.

EFFICIENCY RATING

Up to **20.50 SEER** (Seasonal Energy Efficiency Ratio).

WARRANTY**

10-year limited warranty on the compressor and all remaining covered components.

5-YEAR COOLING SAVINGS

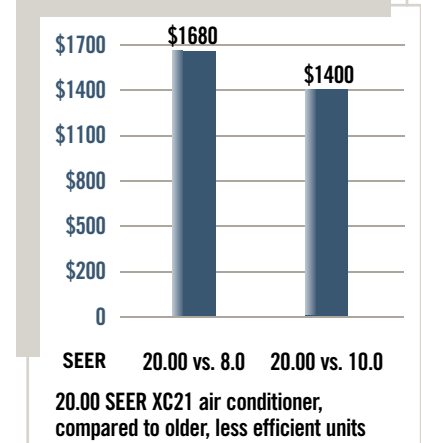

This chart compares the 5-year savings you can expect from an XC21 air conditioner vs. units with lower efficiency ratings, based on a 36,000 Btuh/3-ton unit (EPA Region 9). Your actual savings will vary depending on the weather, local fuel rates, indoor coil, and your lifestyle.

Source: U.S. Department of Energy national average energy rates.

*A combination of sound ratings established per ARI's test standard: 270 and efficiency ratings established per ARI's test standard: ANSI/ARI 210/240-94.

**Applies to residential applications only. See actual warranty certificate for details.

***10 SEER air conditioner

Quiet **Approximately 13 times quieter than a standard air conditioner**

The XC21 is engineered with exclusive SilentComfort™ technology for quiet performance. A patent-pending fan design, two-stage operation, and an insulated compressor compartment also keep sound at a minimum.

Responsible **Conserves energy, while preserving the environment**

The Copeland Scroll Ultra Tech™ compressor uses the new R410A refrigerant, which meets the EPA's standards for ozone and environmental safety.



Customizable **Optimized for use with the new Humiditrol® whole-home dehumidifier**

The XC21 gives you the flexibility to choose a Humiditrol whole-home dehumidifier for improved comfort and indoor air quality. The Humiditrol dehumidifier uses patented technology to provide a level of humidity control never before available.

The Humiditrol dehumidifier also saves you money. Dehumidified air feels cooler, so you can raise your thermostat setting, lower energy costs and still enjoy great comfort. According to the U.S. Department of Energy, you can save 5-7% on your monthly cooling bill for every two degrees you raise your thermostat.



The Humiditrol dehumidifier also helps to reduce the opportunity for mold and mildew problems present in humid conditions. It customizes your cooling system, providing indoor air quality you can *feel*.

SOUND INTENSITY



A traditional air conditioning unit is up to 13 times louder than the XC21.

Note: Manufacturers' public ratings. Typical 80 dB air conditioner/heat pump vs. XC21 operating at 69 dB.

SUPERIOR MOISTURE CONTROL



SignatureStat™ Home Comfort Control removes up to 75 gallons per day when combined with select equipment.

When combined with a *SignatureStat™* home comfort control† and Humiditrol® whole-home dehumidifier, the XC21 air conditioner can remove up to 75 gallons of moisture from the air per day without overcooling your home like competing systems.

†*SignatureStat™* is required for proper operation of the Humiditrol® system on split system air conditioners and heat pumps. *SignatureStat* will not control the packaged rooftop unit version of the Humiditrol system.



Reliable Features the exclusive Lennox® System Operations Monitor

Similar to automobile diagnostics, this monitor continually measures system performance, helping technicians solve problems faster and more accurately. It can even send a “Check System” indicator to select thermostats, letting you know when service is needed.

That’s the kind of worry-free performance Lennox’ promise of quality delivers.



Leading the way in comfort and energy efficiency

For the third consecutive year, the EPA has selected Lennox as an ENERGY STAR® Manufacturing Partner of the Year for Lennox’ ongoing commitment to producing high-efficiency products and features. Lennox is the only HVAC (heating, ventilation, and air conditioning) manufacturer ever to be chosen for this annual award.



CUSTOMIZED COMFORT

The industry’s first integrated home comfort solution

The XC21 Air Conditioner works with other Lennox® products in a system customized for the needs of your home and lifestyle, providing temperature and humidity control and the cleanest, healthiest air possible.

G61V Variable Speed Furnace is the quietest furnace you can buy.††

PureAir™ Air Purification System cleans the air in your home better than any other single system you can buy.

SignatureStat™ Home Comfort Control combines the functions of a humidistat and thermostat into a single device.

Harmony III™ Zoning System provides customized, room-to-room comfort.

Humiditrol® Whole-Home Dehumidifier offers enhanced moisture control and air quality.

Dave Lennox Signature™ Collection XC21 Specifications

XC21	024	036	048	060
SEER	Up to 20.50	Up to 20.00	Up to 18.10	Up to 17.00
Sound Rating – dB	69	71	73	73
Dimensions HxWxD (in.)	47 x 35-1/2 x 39-1/2	47 x 35-1/2 x 39-1/2	47 x 35-1/2 x 39-1/2	47 x 35-1/2 x 39-1/2
HxWxD (mm)	1194 x 902 x 1003	1194 x 902 x 1003	1194 x 902 x 1003	1194 x 902 x 1003

Note: Due to Lennox’ ongoing commitment to quality, all specifications, ratings and dimensions are subject to change without notice.

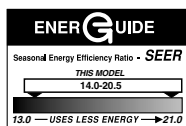

Many Lennox® home comfort systems meet ENERGY STAR® requirements when used with appropriate components. Ask your dealer for details.



Certification applies only when used with proper components as listed with ARI

††Based on sound pressure levels during steady-state, high-fire operation of Lennox G61MPV-36B-070 and leading competitive units at midpoint temperature rise and minimum external static pressure when set up per Section 4.5.3 of ARI 260.

OUTSTANDING FEATURES FOR EXCEPTIONAL QUALITY, COMFORT AND EFFICIENCY

SilentComfort™ Fan Grille –

Uses patent-pending, vortex-suppression technology to reduce sound of airflow exiting unit, providing a quieter environment outside your home.

Factory-Installed Lennox® System Operations Monitor –

Continually reviews system performance to allow fast troubleshooting, which assures you of worry-free performance.

SilentComfort™ Fan Blade with Variable Speed Direct-Drive Blower –

Provides ultra-quiet, energy-efficient operation with a patent-pending design.

Insulated Compressor Compartment –

Minimizes operating sounds with innovative materials and industry-leading, vibration-isolating mounts.

Copeland Scroll Ultra Tech™ Two-Stage Compressor –

Operates at low stage most of the time for quieter, more efficient performance. Plus, it cools your home using the ozone-responsible R410A refrigerant.

High-Efficiency Outdoor Coil –

Provides exceptional heat transfer and low air resistance for high-efficiency operation that can lower your cooling bills.

SmartHinge™ Louvered Coil Protection –

Allows quick, easy access to interior components from all sides, so the unit can be serviced in minimal time, saving you money.

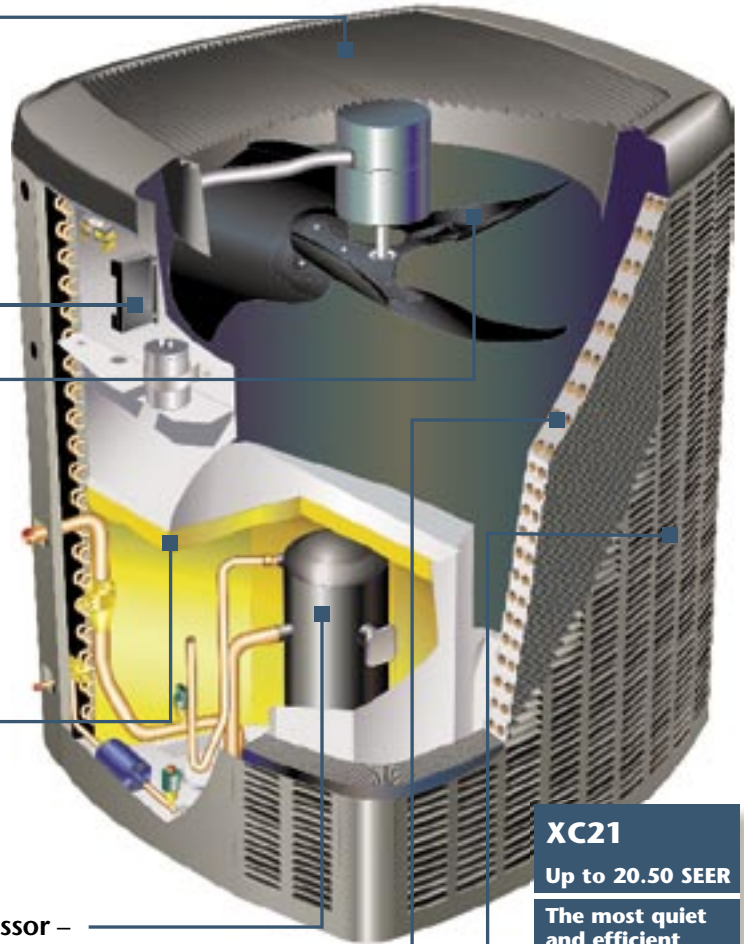

XC21
Up to 20.50 SEER
The most quiet and efficient central air conditioner you can buy.*



Quality you can trust.
Constructed of heavy-gauge, pre-painted steel and tested in the most extreme environments to ensure maximum durability.

*A combination of sound ratings established per ARI's test standard: 270 and efficiency ratings established per ARI's test standard: ANSI/ARI 210/240-94.



- 1 Air conditioner or heat pump
- 2 Thermostat
- 3 Furnace or air handler
- 4 Filtration device
- 5 Germicidal light
- 6 Indoor coil
- 7 Humidifier
- 8 HEPA bypass filtration system
- 9 Energy recovery ventilator
- 10 Supply duct
- 11 Return duct
- 12 Dehumidifier system

CUSTOMIZE YOUR COMFORT

Lennox® heating, cooling and indoor air quality products are designed to provide efficient, economical comfort—not only as individual units, but also together as an integrated system. This combined network of products delivers on every comfort count, from consistent temperatures and balanced humidity to improved indoor air quality.

DEALERS YOU CAN COUNT ON

Choosing the right dealer for your home's heating, cooling and air quality needs is every bit as important as choosing the right brand. We think you'll agree our independent dealers are a big reason you can count on quality customer service whenever you call. Your Lennox dealer's dedication to quality shows in his knowledge, training and expertise in designing the right system for your home, installing it properly and keeping it running perfectly for many years to come.



HOME COMFORT SYSTEMS
Innovation never felt so good.™

© Lennox Industries Inc. 2005

Visit us at www.lennox.com, or contact us at 1-800-9-LENNOX.